

GAS PILOT IGNITION AND FLAME DETECTION SYSTEM Installation and Operation Manual

FastFlame™



Part Numbers:

04002002-12

04002002-10

04002002-FR

**KEEP THIS MANUAL IN A SAFE PLACE
FOR FUTURE REFERENCE**

READ THIS MANUAL BEFORE USING THIS PRODUCT. FAILURE TO FOLLOW THE INSTRUCTIONS AND SAFETY PRECAUTIONS IN THIS MANUAL CAN RESULT IN SERIOUS INJURY OR DEATH OR DAMAGE TO EQUIPMENT.

Chentronics® LLC
50 O'Hara Drive
Norwich, NY 13815, USA
TEL: +1.607.334.5531
info@chentronics.com
www.chentronics.com

Contents

1.0 Important Safety Information.....	3
2.0 Definitions.....	9
3.0 Chentronics® High Energy Ignition Systems	9
4.0 System Specifications	10
4.1 Description of Equipment	10
4.2 Description of Equipment Protective System	11
4.3 Equipment Conditions of Use	11
4.4 Electrical Area Classification and Safety Markings.....	12
4.5 System Electrical and Physical Specifications.....	13
5.0 Installation Instructions.....	15
5.1 Igniter Installation.....	15
5.2 Flame Rod Harness Installation.....	15
5.3 Power and Control Wiring Installation.....	16
5.4 Terminal Block Connections.....	17
5.5 Equipment Earth Bond Locations.....	18
5.6 System Schematic Diagram.....	21
6.0 System Operational Inputs and Outputs.....	22
6.1 Applying Power to Equipment	22
6.2 Flame Detection Feedback.....	22
6.3 Flame Strength Signal Feedback	23
6.4 Commanding Exciter to Spark.....	24
6.5 Spark Detection Feedback	25
6.6 System LED Indicators.....	26
7.0 Standard Components and Accessories	27
7.1 Standard System Components.....	27
7.2 Standard Accessories	27
8.0 Warranty Instructions.....	27
9.0 Technical Support.....	27

1.0 Important Safety Information



Read All Instructions before Using Equipment



The instructions provided in this manual have been prepared to serve as a general guide. It is intended for use by qualified personnel with knowledge of equipment of this type. It is not intended to cover all possible variations in equipment or to provide for specific operating problems which may arise.

You are responsible for adhering to all warnings or cautions provided in this Manual.

In addition to any general safety measures provided in this Manual, you must comply with all current national, state, local and company safety regulations at all times.

Safety Symbols used in this manual comply with ISO 3864.

THESE SYMBOLS ARE USED TO ALERT YOU TO POTENTIAL PERSONAL INJURY HAZARDS.

OBEY ALL SAFETY MESSAGES THAT FOLLOW THESE SYMBOLS TO AVOID POSSIBLE INJURY OR DEATH.



Indicates a hazard with a high level of risk which, if not avoided will result in death or serious injury.



Indicates a hazard with a medium level of risk which, if not avoided could result in death or serious injury.



Indicates a hazard with a low level of risk which, if not avoided will result in minor or moderate injury.



HAZARDOUS VOLTAGE

The equipment contains a High Energy Ignition System which contains **DANGEROUS AND POTENTIALLY LETHAL VOLTAGE**. To avoid risk of serious injury from electric shock, always follow the safety precautions listed below:

Disconnect power before servicing the equipment.

Ensure the equipment is appropriately bonded to earth before use. See Section 5.5 regarding equipment earth bond locations.

Do not open the equipment's cover when the equipment is energized.

Do not join or separate any connection to the equipment when the equipment is energized.

Do not apply power to the equipment without its cover in place.

Do not apply power to the equipment without an igniter attached or the igniter port appropriately capped.

Keep the igniter firing end away from all personnel and flammable material.

Do not apply power to the equipment without a flame rod harness attached or without the flame rod output appropriately capped.

Do not apply power to the equipment unless the flame rod harness output wire is appropriately terminated in the pilot assembly.

Keep the energized flame rod away from all personnel and flammable material.

The equipment must be installed and serviced by qualified personnel in accordance with applicable local and national codes, standards, and ordinances.

The equipment is not field-repairable. Do not attempt to disassemble or repair the equipment.



 **DANGER**
EXPLOSION HAZARD



Do not open the equipment cover or service the equipment if an Explosive Atmosphere may be present.

The equipment must be installed and serviced by qualified personnel in accordance with applicable local and national codes, standards, and ordinances.

The equipment's enclosure may not be drilled and tapped in the field.

The equipment is not user/field repairable and must be returned to the manufacturer for repair in the event of an equipment malfunction.

Do not disassemble the internal electrical assembly. Improper reassembly of internal components could compromise the enclosure's ability to contain an explosion within the device.

Substitution of components may impair suitability for Class 1 Division 2.

Les symboles de sécurité utilisés dans ce manuel sont conformes à la norme ISO 3864.

CES SYMBOLES SONT UTILISÉS POUR VOUS AVERTIR DES RISQUES DE BLESSURES POTENTIELS. RESPECTEZ TOUS LES MESSAGES DE SÉCURITÉ QUI SUIVENT CES SYMBOLES POUR ÉVITER LES BLESSURES POTENTIELLES OU LA MORT.



Indique un danger avec un niveau élevé de risque qui, s'il n'est pas évité, entraînera la mort ou des blessures graves.



Indique un danger avec un niveau de risque moyen qui, s'il n'est pas évité, pourrait entraîner la mort ou des blessures graves.



Indique un danger avec un niveau de risque bas qui, s'il n'est pas évité, entraînera des blessures mineures ou modérées.



TENSION DANGEREUSE

L'appareil contient un système d'allumage à haute énergie qui contient une **TENSION DANGEREUSE ET POTENTIELLEMENT MORTELLE**. Pour éviter les risques de blessures graves par électrocution, suivez toujours les précautions de sécurité indiquées ci-dessous:

Coupez l'alimentation avant l'entretien du matériel.

S'assurer que l'équipement est correctement mis à la terre avant l'utilisation. Voir la section 5.5 concernant l'emplacement des liaisons à la terre de l'équipement.

Ne pas ouvrir le couvercle de l'appareil lorsque l'appareil est sous tension.

Ne pas connecter ou séparer toute connexion à l'équipement lorsque l'appareil est sous tension.

Ne pas appliquer de tension à l'appareil sans son couvercle en place.

Ne pas appliquer de tension à l'appareil sans un allumeur connecté ou le port d'allumage correctement fermé.

Gardez l'extrémité de l'allumeur loin de tout personnel et de matériels inflammables.

Ne pas appliquer de tension à l'appareil sans connecter le câblage électrique de l'électrode de détection de flamme ou sans la sortie de l'électrode de détection de flamme correctement fermé.

Ne pas appliquer de tension à l'appareil à moins que les fils électriques sortant de l'électrode de détection de flamme ne soient proprement raccordés à l'assemblage du pilote.

Maintenir l'électrode de détection de la flamme sous tension loin de tout le personnel et de tout matériel inflammable.

L'équipement doit être installé et entretenu par du personnel qualifié, conformément aux codes locaux et nationaux applicables, aux normes et règlements en vigueur.

L'appareil n'est pas réparable sur site. Ne tentez pas de démonter ou de réparer l'équipement.



RISQUE D'EXPLOSION



Ne pas ouvrir le couvercle de l'équipement ou réparer l'appareil si une atmosphère explosive peut être présente.

L'équipement doit être installé et entretenu par du personnel qualifié, conformément aux codes locaux et nationaux applicables, aux normes et règlements en vigueur.

Le boîtier de l'appareil ne doit pas être percé et taraudé sur site.

L'équipement n'est pas réparable par l'utilisateur/sur site et doit être retourné au fabricant pour réparation dans le cas d'une défaillance de l'appareil.

Ne pas démonter l'assemblage électrique interne. Un réassemblage incorrect des composants internes pourrait compromettre la capacité du boîtier à contenir une explosion dans l'appareil.

La substitution de composants peut nuire à la conformité pour la Classe 1 Division 2.

2.0 Definitions

Spark – An electric current arc.

High Energy Ignition – Electric spark ignition system utilizing high energy sparks for direct ignition of hydrocarbon fuels such as gas, diesel, or #6 oil.

High Energy Exciter – An electronic device that stores electric charge and releases it cyclically in abrupt bursts to an igniter to create high power sparks.

Flame Rectification Detector – An electronic device that detects the rectified current property created by placing two disproportionately sized electrodes in a flame with an AC excitation voltage applied between them.

Flame Rod – Smaller of two electrodes in a Flame Rectification Detector system.

3.0 Chentronics® High Energy Ignition Systems

Chentronics® High Energy Ignition (HEI) systems directly ignite burner fuels by providing short time duration (impulse), high current electrical arcs commonly referred to as *sparks*. These sparks are generated by abruptly releasing electrical energy (charge) stored in large capacitors. The energy is released through an igniter driver circuit called a *pulse forming network* to specialized high energy igniters. The result is a high power spark with increased ability to ignite fuels.

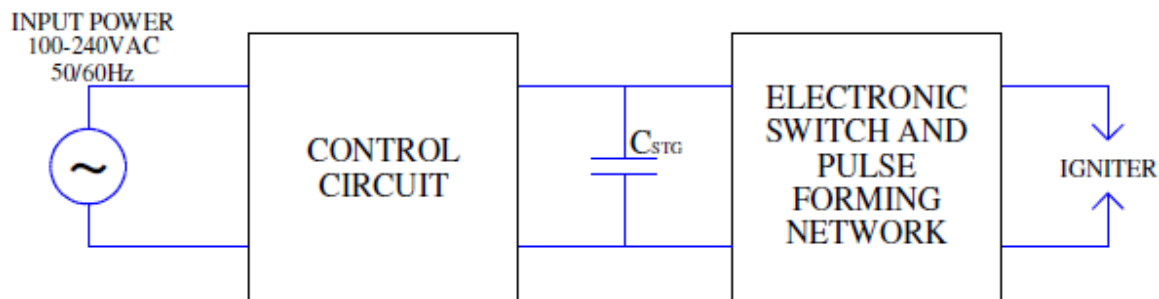

Figure 1: High Energy Exciter basic schematic.

Chentronics® High Energy Ignition Systems are designed to operate in conditions of extreme temperature, moisture, and contamination; creating high power sparks that dependably provide direct spark ignition to a wide range of fuels in a wide range of adverse conditions. The igniter can spark even under water.



Figure 2: Igniter firing in water.

NOTE: Firing igniters submerged in water will cause them to excessively wear and reach end of life very quickly

4.0 System Specifications

4.1 Description of Equipment

The Chentronics® **FastFlame™** gas pilot ignition and flame detection system is comprised of an electronic high energy ignition system and flame rod rectified current type flame detector integrated into one small convenient electronics package. The system is designed to quickly ignite pilot burners in the worst wet and dirty startup conditions while simultaneously detecting and affirming the presence of the resulting burner flame. The system is also designed for direct to pilot mounting via its igniter output. A flame rod harness can be utilized for integration with the flame rod of virtually any pilot. Igniters and flame rod harnesses are available for this integrated system. For associated system component part numbers see Section 7.0.

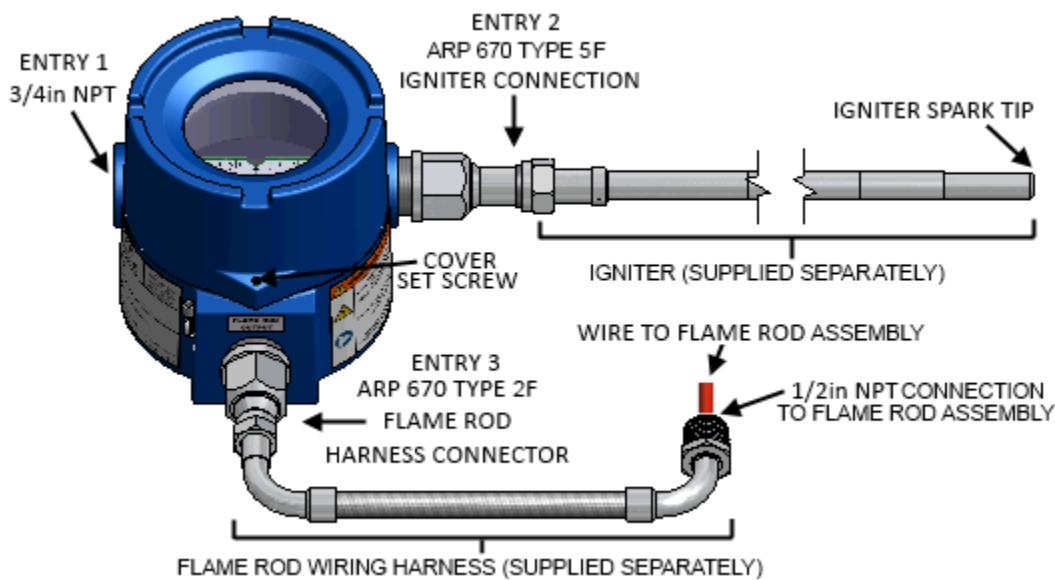

Figure 3: System general arrangement.

The **FastFlame™** system model number 04002002 is available in three configurations:

Model 04002002-12

Configured with ARP 670 Type 5F igniter in Entry 2 and ARP Type 2F flame rod harness connector in Entry 3 as shown in Figure 3.

Model 04002002-10

Configured with ARP 670 Type 5F igniter connection in Entry 2 and a Certified Ex Blanking Element factory installed in Entry 3.

Model 04002002-FR

Configured with ARP 670 Type 2F flame rod harness connection in Entry 3 and a Certified Ex Blanking Element factory installed in Entry 2.

4.2 Description of Equipment Protective System

A flameproof enclosure houses the electrical control and measurement equipment. Two of the three cable entries in the flameproof enclosure are filled with an ARP 670 Type 2F barrier gland, an ARP 670 Type 5F barrier gland, or an Ex Blanking Element. The third entry is for attachment of a field installed power supply. See Section 4.4 for equipment certification and marking information.

4.3 Equipment Conditions of Use

The **FastFlame**™ system equipment is subject to the following conditions of use and limitations:

1. All threaded flame paths (all enclosure entries including cover) must be engaged at least five (5) full threads.
2. The equipment shall not be subjected to source of heating or cooling (process temperature) greater than +85°C, or less than -25°C.
3. The ARP 670 Type 2F connector must be connected to an ARP 670 Type 2M connector, and the ARP Type 5F connector must be connected to an ARP 670 Type 5M connector per the requirements of drawing CERT-CONNECT-ETL-2. All connections must be wrenched to a torque of 50 N-m before the equipment is powered.
4. The equipment's igniter and flame rod connections should not be joined or separated when the equipment is in use (powered).
5. Any connection made to the equipment must have an IP 66 or greater rating.
6. Any unused cable entry on the associated equipment shall be filled with an approved sealing device within 50mm of the enclosure. All sealing fittings must be certified for use as flameproof 'd'.
7. Precautions to avoid electrostatic discharge from the non-metallic nameplate should be minimized and considered by the end user. Please see Section 5.5 regarding earth bond requirements in this manual.
8. No more than one threaded adaptor shall be used on any single entry on the associated equipment.

4.4 **Electrical Area Classification and Safety Markings**

The **FastFlame**™ system has been assessed and complies with the following hazardous area standards:

NEC/CEC

UL 60730-1, UL60730-2-5

CSA-E60730-1

UL 1203

CAN/CSA C22.2#30

ISA 12.12.01

CSA C22.2#213



CLASS I, DIVISION 2, GROUPS B, C, & D

Ta -25°C to +85°C; T5

IECEX

IEC 60079-0

IEC 60079-1

IEC 60079-15



Ex d nA IIC T5 Gc IP 66

Ta -25°C to +85°C

IECEX ETL 14.0016X

The **FastFlame**™ system has been assessed and complies with the following safety standards:

NEC/CEC

UL 60730-2-5

CSA C22.2 No. 60730-2-5

ANSI Z21.20



4.5 System Electrical and Physical Specifications

Application:	Gas pilot ignition and flame detection system
Input Power:	100-240VAC 50/60Hz, 0.5A MAX
Exciter Type:	High Energy Ignition
Exciter Duty Cycle:	30sec ON / 2min OFF
Exciter Spark Command:	INPUT - close terminal 3 to 4 with dry relay contacts to start exciter
Exciter Spark Detect Signal:	OUTPUT - Normally Closed, opens approximately 75ms each spark, 240VAC, 200mA
Exciter Spark Detect Visual:	LED, Blue , flashes off approximately 75ms for each successful spark output current detected
Exciter Power:	1.5J per Spark at 5 Sparks per Second Nominal
Flame Detector Type:	For Rectifying Flame Rod type installations
Flame Detector Duty:	Continuous
Flame Detector Relay:	OUTPUT – Normally Open, 240VAC 0.25A, CLOSED = FLAME DETECTED
Flame Detector Visual:	LED, Green=Flame , Red=No Flame , Off=No Power
Flame Detector FDRT:	0.7 seconds MAX
Operating Temperature Limits:	-25C to 85C
Storage Temperature Limits:	-40C to 100C
Humidity:	0 to 100% condensing
Enclosure:	Painted Aluminum, NEMA 4X, IP66, Certified Ex d
Barrier Gland Connectors:	Stainless Steel, NEMA 4X, IP66, Certified Ex d nA
Electronics Assembly Weight:	Approximately 5lb
Dimensions:	Approximately 7.5 x 7 x 5 inches with output connectors





Do not exceed equipment operating specifications. Operating the system outside its prescribed specifications could compromise its hazardous area protective systems and can result in serious injury or death or damage to equipment.



RISQUE D'EXPLOSION

Ne pas dépasser les spécifications de fonctionnement de l'équipement. Un fonctionnement du système en dehors des spécifications prescrites pourrait compromettre ses systèmes de protection pour zone dangereuse et peut entraîner des blessures graves ou la mort ou des dommages matériels.

5.0 Installation Instructions

5.1 Igniter Installation

The **FastFlame™** system is compatible with Chentronics High Energy Igniters that have an ARP 670 Type 5M connection. The equipment has been designed to work best with the system components listed in Section 7.0.

To install the igniter, feed the igniter male connector into the female ARP 670 Type 5F connector on the electronics assembly, then tighten the ARP 670 Type 5M backing nut to a torque of 50Nm. See Figure 4 for details.

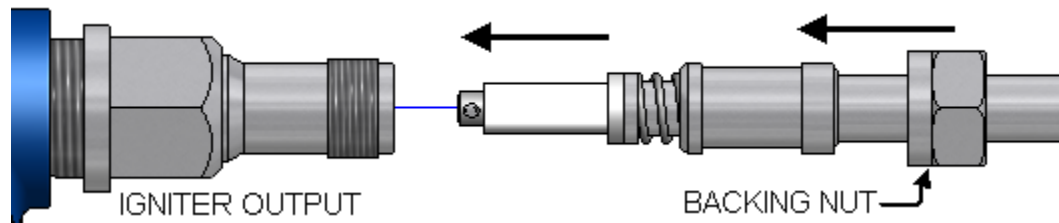

Figure 4: Igniter installation.

The igniter should be installed into the pilot burner with its terminating spark tip end in an electrically unclassified area. Refer to all pilot burner manufacturer instructions before installing equipment on a pilot burner system.

5.2 Flame Rod Harness Installation

The **FastFlame™** system flame rod output is compatible with ARP 670 Type 2M harness connectors. The equipment has been designed to work best with the system components listed in Section 7.0.

To install the harness onto the electronics, feed the harness male connector into the female ARP 670 Type 2F connector on the electronics assembly. Tighten the ARP 670 Type 2M backing nut to a torque of 50Nm. See Figure 5 for details.

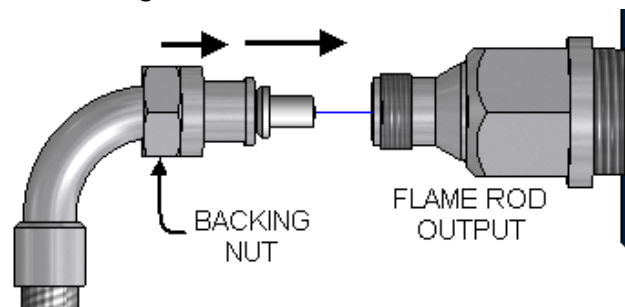

Figure 5: Flame rod harness installation.

Install the ½-inch NPT harness end into the flame rod assembly, terminating in an electrically unclassified area. Refer to all pilot burner manufacturer instructions before installing equipment on a pilot burner system

5.3 Power and Control Wiring Installation

Entry 1 provides a ¾-inch NPT entry for power and control wiring ingress.

To install powering and control wiring to the system, loosen the cover set screw and then remove the equipment cover by turning counter clockwise. Feed power and control wires through Entry 1 and up to the equipment terminal block connectors. See Figure 6 for details. Connect power and control wiring to the terminal block connectors as indicated in Section 0. Tighten terminal blocks to 0.5 N-m (4.4 in-lbs). Replace the enclosure cover and be sure it is fully threaded and seated onto gasket. Tighten cover set screw.

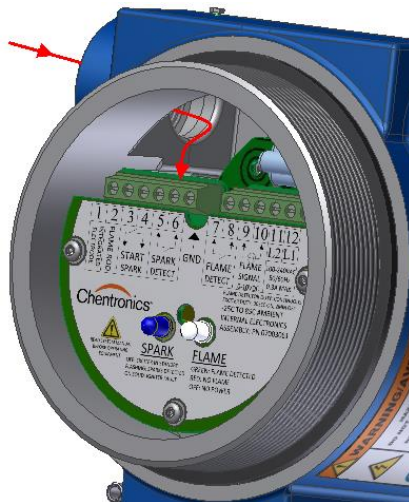

Figure 6: Entry 1 wiring path.



DANGER

EXPLOSION HAZARD





For Class 1 Division 2 hazardous area installations a seal must be installed within 18 inches of the enclosure at Entry 1.

For Zone 2 hazardous area installations wiring in Entry 1 must be sealed per local code requirements using a Certified Ex Cable Gland/Conduit Seal rated Explosion Proof/Flame Proof. Hazardous area sealing devices should be rated for use in **Ex d IIB+H2 T5 Gc Ta -25°C to 85°C** areas.

Use Conductors and Cable Gland/Conduit Seals rated for 90°C minimum.

Failure to install an appropriate barrier gland or conduit seal limits the enclosure's ability to contain an explosion within the device.

RISQUE D'EXPLOSION

Pour les installations en zone dangereuse de classe 1 Division 2, un joint d'isolation et d'étanchéité doit être installé dans les 18 pouces du boîtier à l'entrée 1.

Pour des installations en Zone dangereuse 2, le câblage en entrée 1 doit être scellé suivant les exigences des codes locaux en utilisant un Presse-étoupe/Conduit scellé certifié Ex, isolant et étanche à l'épreuve des explosions/épreuve des flammes. Les dispositifs d'étanchéité pour Zone dangereuse doivent être adaptés pour une utilisation dans les domaines Ex d IIC T5 Gc Ta -25 ° C à 85 ° C.

Utiliser des conducteurs et presse-étoupes / Conduits scellés indiqués pour 90 ° C minimum.

Le défaut d'installation d'un presse-étoupe ou d'un conduit scellé limite la capacité du boîtier à contenir une explosion à l'intérieur de l'appareil.

5.4 Terminal Block Connections

The terminal block connections to the **FastFlame™** system are provided in Table 5.4.1 and shown in Figure 7 below. Terminal screws require a 1/8- inch wide flat blade screw driver. Tighten terminal screws to 0.5 N-m (4.4 in-lbs).

Note: All wiring is to be done in accordance with local and national codes, standards, and ordinances.

Note: Use copper or aluminum conductors only.

5.4.1 Table of System Connections

Item	Terminal Number	Function
Input: Earth	GND, Green Screw	Earth Bond, Use #10 ring terminal, See Section 5.5
Input: Line Power	12 (L1) [18-16 AWG]	Line Input
Input: Line Power	11 (L2) [18-16AWG]	Line Input
Output: Flame Signal	9 to 10 [22-16AWG]	Non-Calibrated 0-10VDC, Terminal 10 is DC Ground. The Flame Detector pulls in at 4VDC nominal

Output: Flame Detect	7 to 8 [22-16AWG]	Normally Open, Closed (Short) = flame detected
Output: Spark Detect	5 to 6 [22-16AWG]	Normally Closed, Opens ~75ms each successful igniter spark
Input: Start Spark	3 to 4 [22-16AWG]	Close (Short) to begin sparking, Terminal 4 is DC Ground
Output: To Flame Rod	2 [22-16AWG]	Factory Wired Flame Rod excitation signal
Integrated Elect.	1 [22-16AWG]	Not used with this equipment model

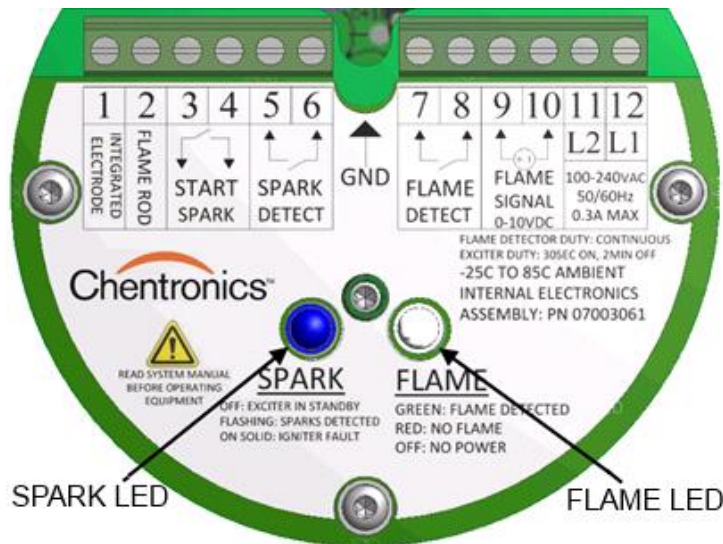

Figure 7: System internal electronics terminals and indicators.

Note: Terminal 1 is unused with this equipment configuration.

Note: Terminal 2 is factory wired to the ARP 670 Type 2F barrier gland. Do not disconnect.

5.5 Equipment Earth Bond Locations

The equipment includes two earth bond connections: one internal to the enclosure and one external. The internal earth bond connection is required for all installations. The external earth bond connection is to be used per local code installation requirements.

5.5.1 Internal Earth Bond

Bond the equipment to earth using the green internal earth bond screw. Use a #10 ring terminal sized for 12AWG wire. Replacement internal earth bond screws must be size #10-24 x ¼-inch. See Figure 8 below showing earth bond locations.

5.5.2 External Earth Bond

Where required by local code, bond the equipment to earth using the external earth bond screw. A size #10 ring terminal for 12AWG wire is supplied with the equipment for this purpose.

Replacement ring terminals must be size #10 for 12AWG wire. Replacement external earth bond screws must be size #10-24 x ¼-inch and stainless steel. See Figure 8 below showing earth bond locations.



Figure 8: Earth bond locations.



DANGER



**EXPLOSION HAZARD
POTENTIAL ELECTROSTATIC CHARGING HAZARD**

Ensure the equipment is properly earth bonded before energizing to prevent a potential buildup of electrostatic charge. A buildup of electrostatic charge can result in potential electrical arcing to earth, which can ignite hazardous atmospheres or result in potential shock hazard from contact with the equipment enclosure.



DANGER



**RISQUE D'EXPLOSION
RISQUE DE CHARGE ELECTROSTATIQUE
POTENTIELLE**

S'assurer que le matériel est correctement mis à la terre avant de mettre sous tension pour éviter une accumulation potentielle de charge électrostatique. Une accumulation de charges électrostatiques peut entraîner de potentiels arcs électriques à la terre, qui peuvent enflammer des

atmosphères dangereuses ou entraîner des risques d'électrocution par contact avec le boîtier de l'équipement.

5.6 System Schematic Diagram

The following schematic block diagram describes equipment functionality. Terminal blocks for connecting the equipment to installation wiring are numbered in blue circles at left.

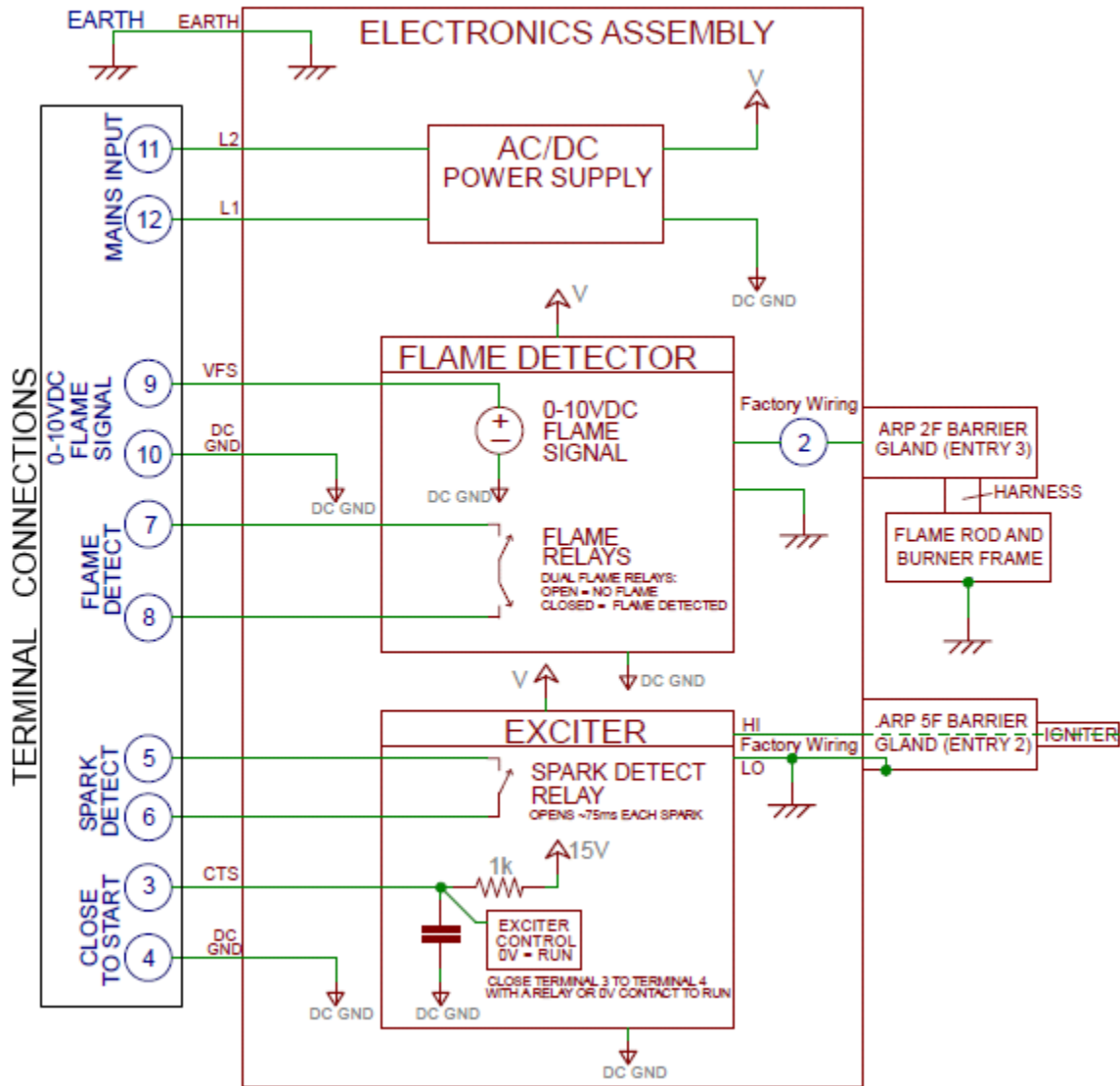

Figure 9: System schematic diagram.

Note: Terminal 1 is unused with this equipment configuration.

Note: Terminal 2 is factory wired to the ARP 670 Type 2F barrier gland. Do not disconnect.

6.0 System Operational Inputs and Outputs

The following functions illustrate the input and output capabilities of the *FastFlame*™ system.

6.1 Applying Power to Equipment

To power the equipment, apply 100-240VAC 50/60Hz from Terminal 11 to 12. The flame detector circuit will power up and begin looking for flame. The exciter circuit will be in Standby Mode.

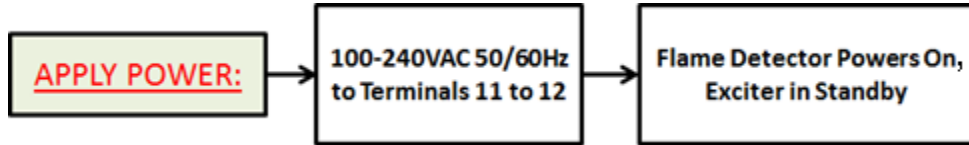

6.2 Flame Detection Feedback

The equipment will close Terminals 7 to 8 when a valid flame signal is registered by the flame detector. The flame detector is operational whenever the equipment is powered. Refer to Section 6.6.1 for information on the Flame LED Indicator functionality.

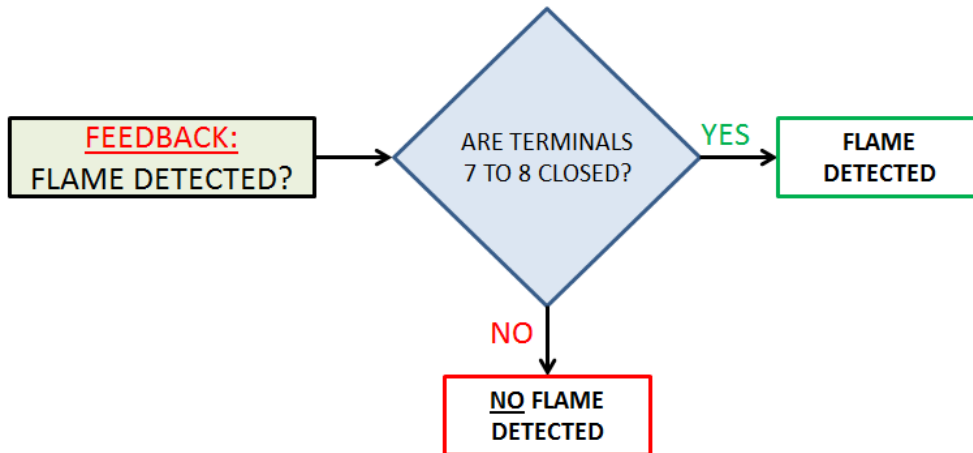







EXPLOSION HAZARD

Verify the flame detector is reporting NO FLAME DETECTED (Flame Relay is OPEN and Flame LED is red) before attempting to start the burner. This verifies that the flame detector is not reporting the presence of flame when there is none. Failure to verify proper operation of the

flame detection system before ignition of a burner could cause an explosion that results in serious injury or death or damage to equipment.







RISQUE D'EXPLOSION

Vérifiez que le détecteur de flamme signale PAS DE FLAMME DETECTÉE (le relais de la flamme est OUVERT et la LED pour la flamme est rouge) avant de tenter d'allumer le brûleur. Cela permet de vérifier que le détecteur de flamme ne signale pas la présence de la flamme quand il n'y en a pas. Ne pas vérifier le bon fonctionnement du système de détection de flamme avant l'allumage d'un brûleur pourrait provoquer une explosion pouvant causer des blessures graves ou la mort ou des dommages matériels.

6.3 Flame Strength Signal Feedback

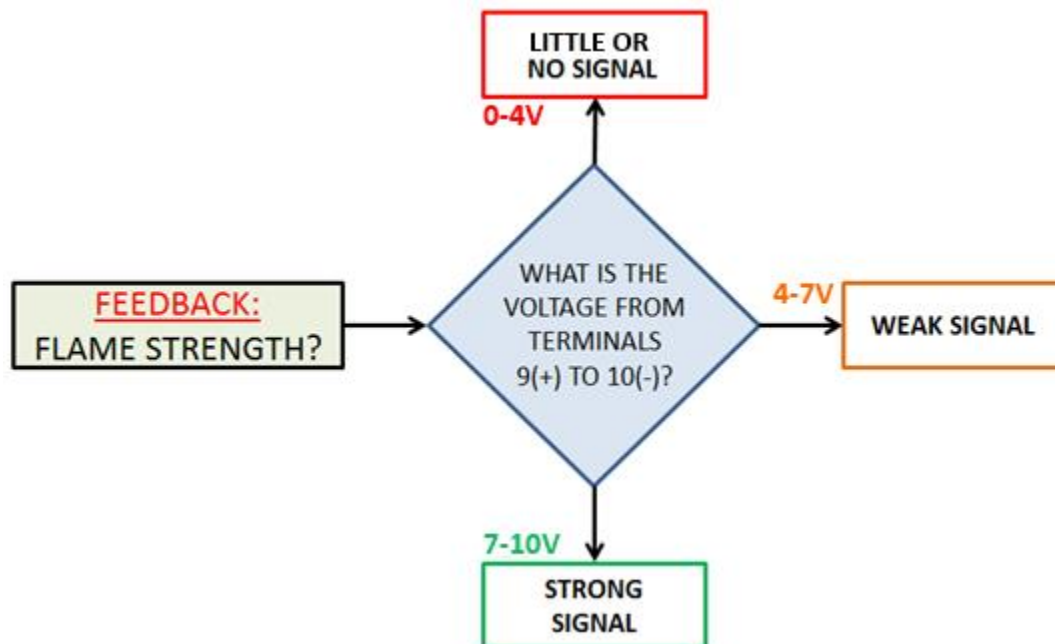
The **FastFlame™** system provides a non-calibrated signal of relative flame strength. When a flame is detected, a voltage level relative to the strength of the flame signal will be present across terminals 9 to 10. The flame signal can be used as a diagnostic tool to trend measured flame signal strength over time.











EXPLOSION HAZARD

The flame strength signal output does not provide proof of flame, and must not be used for proof of flame. Use only the Flame Relay output Terminals 7 and 8 for proof of flame. If the flame strength signal is used for proof of flame, it could provide a misleading result to a control system which could lead to an explosion that results in serious injury or death or damage to equipment.



RISQUE D'EXPLOSION

L'intensité du signal de sortie de la flamme ne fournit pas la preuve de présence de la flamme, et ne doit pas être utilisé comme preuve de la présence de la flamme. Utilisez uniquement les bornes de sorties du relais de la flamme 7 et 8 pour la preuve de présence de flamme. Si le signal d'intensité de la flamme est utilisé pour preuve de présence de flamme, il pourrait donner un résultat trompeur/une information erronée à un système de contrôle qui pourrait conduire à une explosion pouvant causer des blessures graves ou la mort ou des dommages matériels.

6.4 Commanding Exciter to Spark

Closing (shorting) Terminal 3 to Terminal 4 will command the exciter to spark the igniter. The Blue Spark LED on the electronics will turn on when the exciter is attempting to fire and will briefly flash off each time a spark output current is detected.

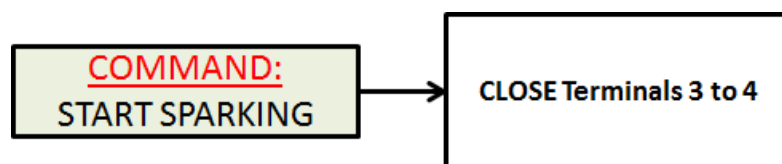

⚠ CAUTION
STARTLING NOISE

Igniters can make a loud “snapping” or “popping” noise when fired. Anticipate this noise and warn others to expect it before operating the equipment. Alert others in area before operating equipment.

⚠ CAUTION

BRUITS SAISSANTS/SURPRENANTS

Les allumeurs peuvent faire un fort bruit de « claquement » ou un bruit «sec» lors de l’allumage. Anticipez ce bruit et avertissez les autres de s’attendre à ce bruit avant de faire fonctionner l’équipement. Alerte tout individu dans la zone avant de faire fonctionner l’équipement.

6.5 Spark Detection Feedback

The *FastFlame*™ system provides spark detection feedback on a spark by spark basis. It can communicate with a user’s control system by opening Terminals 5 to 6 for approximately 75ms each time a spark output current is registered. When the igniter is wearing out, it will begin to skip sparks. This will cause the Spark Detection output to remain closed when the missed sparks occur. When the igniter is completely worn out, Terminals 5 to 6 will never open when attempting to spark. This signal can be integrated with a user’s control system to help determine when igniter are wearing out or are worn out completely. Refer to Section 6.6.2 for more information on the Spark LED indicator functionality.

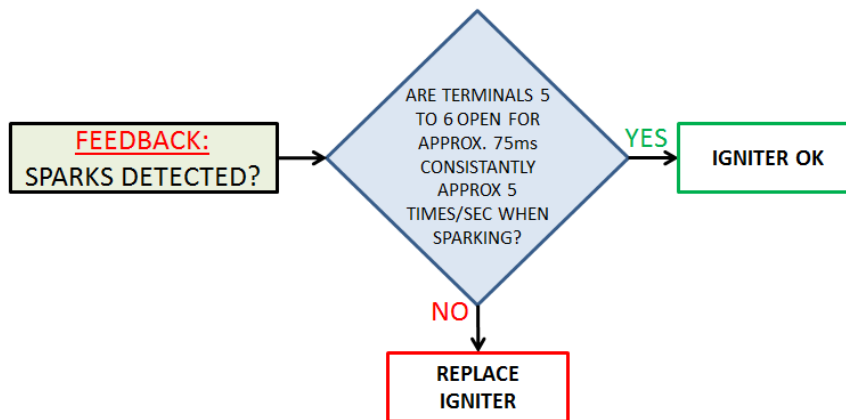

6.6 System LED Indicators

The **FastFlame**™ system is equipped with two LED indicators which will visually represent the functionality of the Flame Detector and Exciter circuits. The LED indicators are on top of the electronics assembly inside the equipment's enclosure and are visible through the enclosure cover's window.

6.6.1 Flame LED Indicator

The Flame LED indicator is on the right side of the internal electronics assembly and is marked with the word "FLAME" below it (see Figure 7). The Flame LED will be **red** when NO flame is detected and **green** when flame is detected. If the Flame LED is not lit, there is no power supplied to the unit.

6.6.2 Spark LED Indicator

The Spark LED indicator is **blue** and on the left side of the internal electronics assembly. It is marked with the word "SPARK" below it (see Figure 7). The Spark LED will be lit when the exciter is attempting to spark the igniter. It will briefly flash off each time a spark output current is detected. When wearing out, the igniter will begin to skip sparks. This can be visually verified by the Spark LED not flashing consistently, or missing blinks. When the igniter is completely worn out, the Spark LED will remain on solidly when attempting to spark. It will be off when the exciter circuit is in standby mode.

7.0 Standard Components and Accessories

The following is a sample of standard parts available for use with the **FastFlame™** system. For additional parts and technical drawings please contact Chentronics®.

7.1 Standard System Components

Igniter – ARP 670 Type 5M connection: PN 01000737.

Flame Rod Harness Kit – ARP 670 Type 2M to ½-inch NPT for connection to flame rod assembly:
PN 03000737.

7.2 Standard Accessories

Flame Simulating Tool – For system diagnostics: PN 07005516.



DANGER
EXPLOSION HAZARD

Flame simulating devices are for equipment troubleshooting purposes only. NEVER use any flame simulating device to provide false flame indication during normal operation. Indication of a flame when one is not present will defeat devices that monitor safe operation of equipment and can result in serious injury or death or damage to equipment.



DANGER
RISQUE D'EXPLOSION

Les dispositifs de simulation de flamme sont uniquement à des fins de dépannage du matériel. NE JAMAIS utiliser un dispositif de simulation de flamme pour fournir une fausse indication de la flamme pendant le fonctionnement normal. L'indication d'une flamme quand il n'y en a pas ira à l'encontre des dispositifs qui contrôlent le fonctionnement en sécurité de l'équipement et peut entraîner des blessures graves ou la mort ou des dommages matériels.

8.0 Warranty Instructions

For warranty related inquiries please contact Chentronics® at TEL: +1.607.334.5531 or info@chentronics.com

9.0 Technical Support

For technical support related inquiries beyond the scope of this Installation and Operation Manual, please contact Chentronics® at **TEL: +1.607.334.5531** or info@chentronics.com