

PRODUCT MANUAL



Figure 1: Base iScan3+ Model



Figure 2: Fiber Optic Compatible iScan3+ Model


Contents



1 Warnings	5
2 Definitions	6
3 Product Features	6
3.1 Available Options	6
3.1.1 Root Part Number	7
3.1.2 Material Options	7
3.1.3 Bluetooth Options.....	7
3.1.4 Functional Configurations (MB/SB).....	7
3.2 Communication Methods	8
3.2.1 Relay Contacts (Flame and Fault).....	8
3.2.2 Bluetooth	8
3.2.3 RS-485/USB	9
3.2.4 Signal Output: 4-20 mA.....	9
3.2.5 MODBUS User Serial Commands.....	9
3.3 User Software.....	10
3.3.1 Desktop Application (<i>iScan Software</i>).....	10
3.3.2 Mobile App (<i>iScan Live</i>).....	10
3.4 Programmable Settings.....	10
3.4.1 Configuration File Select	11
3.5 Temperature Protection (<i>TempProtect</i>)	11
3.6 LED Status Display (“Ring of Light”)	12
3.7 Ease of Installation / Backwards Compatibility.....	14
4 Technical Specifications.....	14
4.1 Electrical and Performance Specifications	14
4.2 Mechanical and Environmental Specifications	15

4.3 Default Response Times.....	15
4.4 Communication Specifications.....	16
5 Certifications	17
5.1 Product Markings.....	17
5.2 Safety Ratings.....	20
5.2.1 Ordinary Area.....	20
5.2.2 Safety Integrity Level (SIL3) [PENDING]	20
5.3 Hazardous Area	20
6 Installation Instructions.....	21
6.1 Mounting iScan3+	21
6.2 I/O Harness Installation.....	22
6.2.1 Ordinary Area and Zone 2 Installation	22
6.2.2 Division 2 Installation.....	23
6.3 Wiring Instructions.....	24
6.3.1 Wiring Diagram (4-wire config file select)	25
6.3.2 Wiring Diagram (2-wire config file select)	26
6.4 RS-485 Wiring Configurations	27
6.4.1 Daisy Chain Wiring Configuration	28
6.4.2 Split (Y Chain) Wiring Configuration	29
6.5 Configuration File Select Wiring.....	30
6.5.1 Four-Wire Input (Two Control Relays).....	31
6.5.2 Two-Wire Input (One Control Relay).....	32
6.5.3 Wire Color Maps	33
6.6 Initial Setup of the iScan3+	35
6.6.1 Aiming an SB/SB4 Model	35
6.6.2 Aiming an MB Model	35
6.6.3 Advanced Aiming	36

7 Product Maintenance.....	37
7.1 Cleaning the Lens	37
7.2 Cleaning the Enclosure.....	38
7.3 SIL Proof Testing [PENDING].....	38
8 Accessories.....	38
9 Technical Support.....	39
9.1 Troubleshooting Guide.....	39
9.2 Warning and Fault Operation.....	40
9.3 Special, “X” Conditions of Use	40
9.4 Warranty Instructions	40
10 Appendix A: MODBUS User Message	41
10.1 PC COM Port Settings.....	41
10.2 MODBUS Function Code and Registers.....	41
10.2.1 MODBUS Function Code	41
10.2.2 Input Register Address	42
10.3 Common Structures and Bit Fields	44
10.3.1 Flame Status, Fault and Warning Bit Field	44
10.3.2 First Out Byte Information	44

1 Warnings

 WARNING		
		<ul style="list-style-type: none">• EXPLOSION HAZARD• DO NOT CONNECT OR DISCONNECT WHEN ENERGIZED• SEPARATE ONLY IN A NON-HAZARDOUS AREA• POTENTIAL ELECTROSTATIC CHARGING

 READ MANUAL BEFORE USE	
	<ul style="list-style-type: none">• FAILURE TO FOLLOW THE INSTRUCTIONS AND SAFETY PRECAUTIONS IN THIS MANUAL CAN RESULT IN SERIOUS INJURY, DEATH, OR DAMAGE TO EQUIPMENT.• THE INSTRUCTIONS IN THIS MANUAL SERVE AS A GENERAL GUIDE AND ARE INTENDED FOR USE BY QUALIFIED PERSONNEL WITH KNOWLEDGE OF EQUIPMENT OF THIS TYPE• IT IS NOT INTENDED TO COVER ALL POSSIBLE VARIATIONS IN EQUIPMENT OR TO PROVIDE FOR SPECIFIC OPERATING PROBLEMS WHICH MAY ARISE• YOU ARE RESPONSIBLE FOR ADHERING TO ALL WARNINGS OR CAUTIONS PROVIDED IN THIS MANUAL• IN ADDITION TO ANY GENERAL SAFETY MEASURES PROVIDED IN THIS MANUAL, YOU MUST COMPLY WITH ALL NATIONAL, STATE, LOCAL, AND COMPANY SAFETY REGULATIONS

Safety Symbols used in this manual comply with ISO 3864.

THESE SYMBOLS ARE USED TO ALERT YOU TO POTENTIAL PERSONAL INJURY HAZARDS.

OBEDI ALL SAFETY MESSAGES THAT FOLLOW THESE SYMBOLS TO AVOID POSSIBLE INJURY OR DEATH.



Indicates a hazard with a high level of risk which, if not avoided will result in death or serious injury.



Indicates a hazard with a medium level of risk which, if not avoided could result in death or serious injury.



Indicates a hazard with a low level of risk which, if not avoided will result in minor or moderate injury.

2 Definitions

Table 1: Definitions	
FOX	Shorthand for “Fiber Optics”. Often used to describe specific applications or configurations of the iScan3+.
Flicker	“Flicker” or “Flicker Frequency” refers to the modulation of flame intensity due to micro-explosions.
Flame ON Response Time (FORT)	The time it takes the flame relay contacts to close after the flame signal rises above the set threshold.
Total Flame Failure Response Time (TFFRT)	The time it takes the flame relay contacts to open after the complete loss of a sensed flame.
Marginal Flame Failure Response Time (MFFRT)	The time it takes the relay contacts to open after the flame signal drops below the set threshold.
Ring of Light (ROL)	Multi-colored LED status indication on the back of the scanner.
iScan® Software	Communications software for PC, used to monitor and configure the iScan3+ Flame Scanner.
iScan® Live	iScan3+ mobile app, used to monitor the iScan3+ Flame Scanner.
MB	Acronym for a “multi burner” scanner which offers full user adjustability for multi-burner (complex) applications.
SB	Acronym for a “single burner” scanner which offers basic user adjustability for single (“simple”) burner applications.
Purge Air Pressure	The minimum differential pressure required between the purge air supply pressure at the scanner connection and the back pressure.

3 Product Features

iScan3+ flame scanner is designed to detect flame over a wide range of applications and fuels, such as oil, natural gas, refinery gas, various gas blends and hydrogen.

iScan3+ consists of an integrated viewing head and signal processor. No secondary signal processor or amplifier is required.

3.1 Available Options

iScan3+ is offered with numerous ordering options:

- Ordering options are configured via a suffix appended to the base part number.
- Please refer to the sales drawing for suffix configuration instructions.
- Ordering options are described in the following sections.

3.1.1 Root Part Number

The iScan3+ is offered in two major configurations with the following root part numbers:

- **04005100:** This is the **standard** iScan3+ model.
- **04005200:** This model has been configured for applications that require the use of a Fiber Optic (FOX) Assembly.

Both models electrically operate the same and carry the same Technical Specifications and Certifications.

Drawings corresponding to these part numbers are available upon request.

For information on configuring a FOX scope of supplies, an application guide is available upon request.

3.1.2 Material Options

- The **standard configuration** of iScan3+ is offered with a 304 stainless steel enclosure.
- iScan3+ is also offered with an option for a 316 stainless steel enclosure. 316 stainless steel versions are available as special-order, please contact Chentronics for more information.

3.1.3 Bluetooth Options

- The standard factory configuration of iScan3+ includes Bluetooth communication. This feature allows wireless connection via the *iScan Live* mobile application.
- iScan3+ is available factory configured without the Bluetooth feature.

3.1.4 Functional Configurations (MB/SB)

iScan3+ is offered in three functional configurations as described in this section.

Refer to **Table 9** for response times.

Refer to Error! Reference source not found. for the list of programmable features.

Multi-burner (MB)

- Required for applications in which equipment has more than one burner or source of radiation, and flame discrimination is required.
- Common applications include wall fired, opposed wall fired, and tangentially fired burners.

- Individual scanners are programmed to detect target flame characteristics and to ignore background flames and radiation.
- Scanners are programmed using the *iScan Software* desktop app.

Single-burner (SB)

- Used in applications in which there is no other source of combustion other than the target flame.
- Common applications include single burner packaged boilers, thermal oxidizers, kilns, and duct burners.
- This model is designed for simple “plug-and-play applications.

Single-burner with 4 second response (SB-4)

- Same as the “SB” configuration except with different timing presets.

3.2 Communication Methods

iScan3+ is equipped with several communication methods as described in the following sections.

3.2.1 Relay Contacts (Flame and Fault)



DANGER

- ONLY THE **FLAME RELAY CONTACT** MAY BE USED TO PROVE FLAME
- ALL OTHER COMMUNICATIONS ARE INFORMATIONAL ONLY. DO NOT USE TO PROVE FLAME

Flame Relay Contact: used to prove flame status (on or off) to the user’s burner control system.
Only this contact may be used to prove flame on/off status for burner management system control.

Fault Relay Contact: used to flag a fault in the unit to the user’s control system.

Refer to **Table 7** for relay ratings.

3.2.2 Bluetooth

Used to communicate wirelessly via the *iScan Live* mobile application.

3.2.3 RS-485/USB

- Used to communicate with a PC running the *iScan Software* desktop app
 - Refer to **Section 3.3.1** for more information
- Requires a USB to RS-485 converter
 - Refer to **Section 8** for ordering information
- Refer to **Table 10** for network specifications

3.2.4 Signal Output: 4-20 mA

- iScan3+ is a current source device only
- Output #1: 4-20 mA, flame strength
- Output #2: 4-20 mA, selectable as gain or internal temperature
- Both outputs are referenced to DC Return (-)
- Max. connected load: 750 ohms



1. 4-20 MA OUTPUTS ARE CALIBRATED AT THE FACTORY TO A KNOWN LOAD.
2. MONITORING HARDWARE WILL HAVE AN IMPACT ON THE CURRENT OUTPUT.
3. FOR ACCURATE READINGS, 4-20 MA OUTPUT(S) SHOULD BE CALIBRATED USING A MILLI-AMMETER BETWEEN THE SCANNER'S 4-20 MA OUTPUT AND THE MONITORING HARDWARE.
4. FOR DETAILS ON EXECUTING THE CALIBRATION PROCEDURE, REFER TO THE 4-20 MA SETTINGS SECTION OF MNL-ISCAN SOFTWARE.

3.2.5 MODBUS User Serial Commands

- iScan3+ can provide operational data via standard MODBUS compliant serial communication messaging via the RS-485 connection.
- Refer to **Section 10** for more information.

**DANGER**

MODBUS SUPPLIED DATA ***MAY NOT*** BE USED TO PROVE FLAME.
ONLY THE FLAME RELAY CONTACT MAY BE USED TO PROVE FLAME.

3.3 User Software

3.3.1 Desktop Application (iScan Software)

- iScan3+ has several settings that are user programmable. This is accomplished via a Windows-based desktop app.
 - Please refer to **Error! Reference source not found.** for a list of programmable settings.
- For in-depth information of how to use the desktop application, please refer to the iScan Software user manual, document number: **MNL-iScan Software**.

3.3.2 Mobile App (iScan Live)

- Available for smartphones and tablets running iOS and Android operating systems.
- The user may read live data, record it, save it to their device, and email the recordings directly from the app.
- For in-depth information of how to use the mobile app, please refer to iScan® Live Mobile App user manual, document number: **MNL-iScan Live**.

3.4 Programmable Settings

Settings that may be changed by a user varies by scanner configuration. Refer to **Table 9: Response Times** for response times.

Table 2: User Programmable Settings			
Feature	Configurations		
	MB	SB	SB4
Flame On Response Time (FORT)	Yes	Yes	Yes
Flame Failure Response Times, Marginal (MFFRT) and Total (TFFRT)	Yes	Yes	Yes
4-20 mA signal mapping	Yes	Yes	Yes
4-20 mA calibrate	Yes	Yes	Yes
4-20 mA gain	Yes	Yes	Yes
Signal gain	Yes	No (Always set to auto)	No (Always set to auto)
Signal frequency	Yes	No	No
Signal threshold	Yes	No	No
Configuration file select (max 4)	Yes	N/A	N/A

3.4.1 Configuration File Select

iScan3+ provides a means for selecting configuration files stored onboard the unit.

Refer to **Section 6** for setup instructions.



3.5 Temperature Protection (*TempProtect*)

iScan3+ has been tested and certified to operate safely within the temperature range as described in **Table 8**.

iScan3+ is designed with protections to ensure the device's safety even in temperatures outside of its rated operating temperature range. Refer to **Section 9.2** for more information on iScan3+ temperature protections.

iScan3+ will report out temperature states in a few different manners:

1. Via the LED Status Display, refer to **Section 3.6** for behavior examples.
2. Via the 4-20 mA signal, Safety Relays, and Fault Relay, refer to **Section 9.2**.

3.6 LED Status Display (“Ring of Light”)

iScan3+ is equipped with an LED status display that mirrors the 4-20 mA signal indicating operating modes to a user.

An operator can quickly recognize operational status, marginal conditions and changes to conditions (such as low flame strength and/or high gain).

This also aids with proper aiming of the scanner. Refer to **Section 6.6** for more information on aiming.

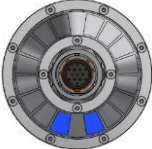
Table 3: Boot up			
Description	Left Side	Right Side	RoL
Bluetooth initialization during startup	One blue LED	One blue LED	



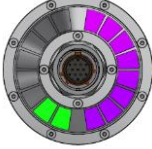

Table 4: Flame ON Examples			
Description	Left Side	Right Side	RoL
Detecting a strong flame.	Flame signal is strong (eight green LEDs)	Gain level is low (two purple LEDs)	
Detecting a good flame.	Flame signal is strong (eight green LEDs)	Gain level is high (eight purple LEDs)	
Detecting a weak flame.	Flame signal is low (two green LEDs)	Gain level is high (eight purple LEDs)	
Approaching an over or under temperature condition. Still operating within the rated temperature range. Still detecting flame.	Flame signal is strong (eight green LEDs)	Gain level is no longer visible on the Ring of Light (eight yellow LEDs, blinking)	


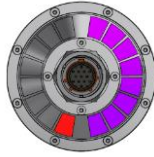



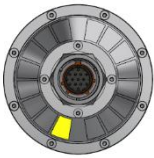
Table 5: Flame OFF Examples			
Description	Left Side	Right Side	RoL
No flame detected.	No flame (one red LED)	Gain level is set at a low level. This is a default for MB models. (one purple LED)	
No flame detected.	No flame (one red LED)	Gain level is either manually set at a high level or is set in "Autogain" mode. (eight purple LEDs)	
Approaching an over or under temperature condition. Still operating within the rated temperature range. No flame detected.	No flame (one red LED)	Gain level is no longer visible on the Ring of Light (eight yellow LEDs, blinking)	

Table 6: Fault Examples			
Description	Left Side	Right Side	RoL
Temperature fault	All LEDs yellow and blinking		
Fault	One yellow LED, blinking	No LEDs	
iScan3+ has been disabled and must be replaced	One LED, solid	No LEDs	

Refer to **Section 9.1** for more information on using the RoL for troubleshooting.


Refer to **Section 9.2** for more information on Warnings and Faults.

3.7 Ease of Installation / Backwards Compatibility

- iScan3+ is fully backwards compatible with iScan3 installations and may be used as a drop-in replacement.
- iScan3+ uses the same I/O Harness as the iScan3 with no re-wiring necessary.
- iScan3+ mounts via a size 1 cam-and-groove connection. Refer to **Section 6.1** for more details.

4 Technical Specifications

4.1 Electrical and Performance Specifications

Table 7: Electrical and Performance Specifications	
Input Power	24 VDC nominal (20-28 VDC), 140 mA MAX, 3.4W MAX Note: power supply to must not include any inductive load
Relay Ratings	<p>Safety Relays: SPDT, normally open (N.O.) and normally closed (N.C.) voltage free (two relays internally configured for redundancy) Fault Relay: SPST, normally open (N.O.), voltage-free contacts</p> <p>1.0A @ 24 VDC Resistive Load† 0.5A @ 48 VDC Resistive Load† 0.25A @ 125 VAC Resistive Load</p> <p>Note: To achieve higher relay contact voltages, use the relay contacts to energize the coil of an interstitial relay.</p> <p>†SELV Compliant</p>
 DANGER ONLY THE <u>SAFETY RELAY CONTACTS</u> ARE TO BE USED TO PROVE FLAME	
4-20 mA Output Maximum Current Loop Resistance	750 ohms
Input Cable	Quick Disconnect
Sensor Type	Solid-State
Sensor Range	300 nm to 750 nm

4.2 Mechanical and Environmental Specifications

Table 8: Mechanical and Environmental Specifications	
Temperature Range	-40°C [-40°F] to +85°C [+185°F]
Ingress	IP66, Type 4X
Humidity	0 to 100% Relative Humidity, Condensing
Weight	3.4 lbs [1.5 kg]
Mounting	1 NPT cam lock
Field of View	6 Degrees
Purge Air Pressure	5 scfm (8.5 Nm ³ /hr) 5" w.c. (13 mbar)

4.3 Default Response Times

Table 9: Response Times			
Setting	Default Configurations		
	MB	SB	SB4
Flame ON Response Time (FORT)	Flame ON 2 seconds	Flame ON 2 seconds	Flame ON 1 second
Total Flame Failure Response Time (TFFRT)	Flame OFF 1 second	Flame OFF 1 second	Flame OFF 4 seconds
Marginal Flame Failure Response Time (MFFRT)	Flame OFF 2 seconds	Flame OFF 2 seconds	Flame OFF 4 seconds

*Refer to **Section 3.4** for more information on programmable settings.

4.4 Communication Specifications

Table 10: Communication Specifications	
RS-485 Network Specifications	
Protocol	Half-duplex (two-wire, echo off)
Bus Configuration	Daisy Chain or Split (Y) See Sections 6.4.1 and 6.4.2 for more information
BAUD Rate	19200k
Nodes	A node may consist of a Scanner, USB to RS-485 Converter, and/or an RS-485 Repeater. For installations with greater than 32 nodes, an RS-485 Repeater is required to ensure a strong network signal.
Maximum Number of Scanners on a Network	127*
Maximum Length of a Network Section	4000 ft (1219 m) Note: for lengths greater than 4000 ft, an RS-485 Repeater is required
4-20 mA Specifications	
Output Maximum Current Loop Resistance	750 ohms
Bluetooth Specifications	
Range	45-50 ft, obstructions may affect range

*Refer to **Section 8** for recommended repeater model information

5 Certifications



PLEASE CONTACT CHENTRONICS FOR COPIES OF THE CETLUS AUTHORIZATION TO MARK, EU CERTIFICATES, IECEX CERTIFICATES OF CONFORMITY, ETC.

5.1 Product Markings




Table 11: USA & Canada Markings	
	
Mark	Standards
 USA: CLASS I DIVISION 2 GROUPS ABCD T4 CLASS I ZONE 2 GROUP IIC T4 CLASS I ZONE AEx ec nC IIC Gc T4 IP66 CAN: CLASS I DIVISION 2 GROUPS ABCD T4 CLASS I ZONE 2 GROUP IIC T4 Ex ec nC IIC Gc T4 IP66	UL 60730-1 UL 60730-2-5 ANSI Z21.20 CSA E60730-1 CSA C22.2#60730-2-5 UL 121201 UL 60079-0 UL 60079-7 CSA C22.2#213 CSA C22.2#60079-0

Table 12: European Union Markings




	
Mark	Standards
  II 3G Ex ec nC IIC T4 Gc IP66 -40°C ≤ Ta ≤ +85°C	EN 298 EN 60730-1 EN 60730-2-5 EN IEC 60079-0 EN 60079-7 EN IEC 60079-15 ETSI EN 301 489-1 ETSI EN 301 489-17 EN IEC 63000

Table 13: IEC/IECEx Markings



 	
Mark	Standards
Ex ec nC IIC T4 Gc IP66 -40°C to +85°C IECEx ETL 24.0043X	IEC 60079-0 IEC 60079-7 IEC 60079-15

Table 14: Brazil Markings


	
Mark	Standards
Ex ec nC IIC T4 Gc IP66 -40°C to +85°C NCC 26.0011X	ABNT NBR IEC 60079-0 ABNT NBR IEC 60079-7 ABNT NBR IEC 60079-15

Table 15: Marine Markings



Table 15: Marine Markings	
	
Mark	Standards
	See certificate

Table 16: Other Markings [PENDING]

Table 16: Other Markings [PENDING]	
Mark	Standards
SIL	IEC 61508

5.2 Safety Ratings

5.2.1 Ordinary Area

iScan3+ is rated as a Class C control per the UL/IEC 60730 series of standards for use in safety-critical flame scanning applications.

5.2.2 Safety Integrity Level (SIL3) [PENDING]

SIL evaluation is currently underway for the iScan3+ and this section will be updated once it has been completed.

5.3 Hazardous Area

iScan3+ is rated for use in **Division 2** areas in the United States, Canada, and anywhere that follows the Division System.

iScan3+ is rated for use in **Zone 2** areas in the European Union, Canada, and anywhere that follows EN/IEC Zone systems.

6 Installation Instructions

6.1 Mounting iScan3+

iScan3+ mounts via a size 1 cam-and-groove connection as shown in **Figure 3**.

1. Install female cam-and-groove coupling onto burner front.
2. Insert iScan3+ into coupling.
3. Close the locking levers.
 - a. Optionally, levers may be further secured by inserting cotter pins or tie wire into the two locking holes.
4. It is recommended that iScan3+ be installed such that the Ring of LEDs are oriented as shown in **Figure 4** (red/green on left, purple on right).



Figure 3: Mounting iScan3+



Figure 4: Ring of Light Orientation

6.2 I/O Harness Installation

iScan3+ utilizes a bayonet-style connector to connect the I/O Harness to the electronics.



ENSURE ALL WIRING IS FINISHED AND TESTED BEFORE INSTALLING I/O HARNESS TO MITIGATE DAMAGE CAUSED BY INCORRECT WIRING.

6.2.1 Ordinary Area and Zone 2 Installation

1. Hold I/O Harness by the quick-disconnect collar.
2. Align connector keyways on harness with those on iScan3+.
3. Connect harness to iScan3+ and turn the quick-disconnect collar clockwise to lock the connector in place.



Figure 5: I/O Harness Installation

6.2.2 Division 2 Installation

Division 2 installations require that power connections cannot be removed without the use of a tool. iScan3+ comes standard with a lock nut that meets this requirement.

1. Install I/O Harness per instructions in **Section 6.2.1**.
2. Locate lock nut on iScan3+ and turn counterclockwise until tight against the I/O Harness collar.
 - a. This secures the harness such that it cannot be removed without the use of a tool.

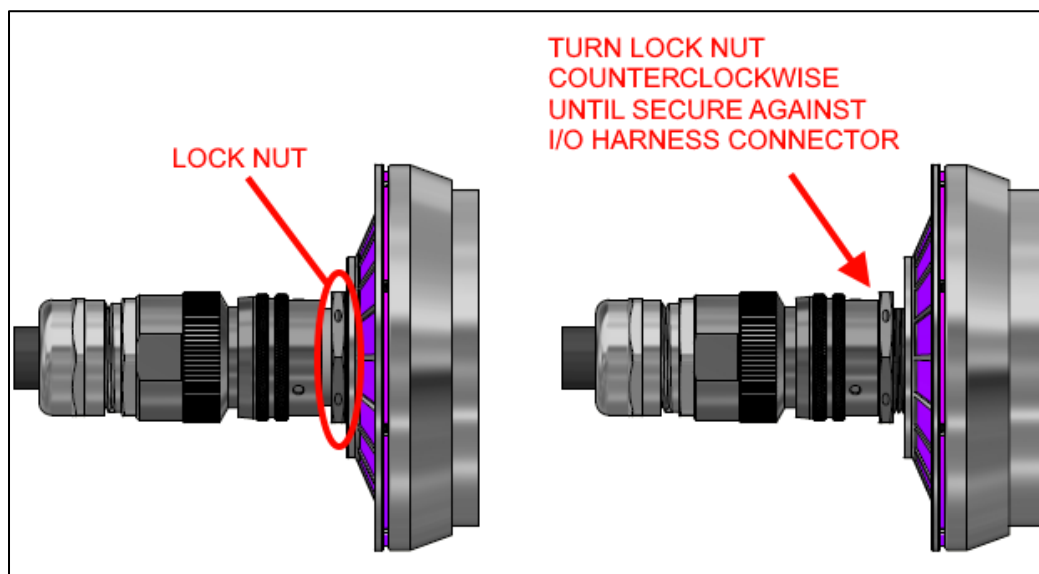


Figure 6: Division 2 Installation

6.3 Wiring Instructions



1. ALL WIRING SHALL BE DONE PER ALL APPLICABLE LOCAL AND NATIONAL CODES, STANDARDS, AND ORDINANCES. THE SCANNER HAS A QUICK CONNECT CABLE.
2. **CONNECTIONS FOR POWER, EARTH GROUND, AND FLAME RELAY (N.O. AND COMMON) ARE NEEDED FOR ALL APPLICATIONS.**
3. USE OF THE 4-20 MA OUTPUTS AND COMMUNICATION CONNECTIONS ARE "AS REQUIRED" FOR EACH APPLICATION.
4. IF MORE THAN ONE 24 VDC SUPPLY IS REQUIRED:
 - a. THE 24 VDC RETURNS LABELED AS "DC (-)" SHALL BE CONNECTED TO EACH OTHER.
 - b. THE 24 VDC SOURCE CONNECTIONS LABELED "DC (+)" SHALL BE ISOLATED FROM ALL OTHER POWER SUPPLIES.
5. IF SWITCHING POWER SUPPLIES ARE USED:
 - a. THE SUPPLIES MAY BE CONNECTED VIA A WIRED OR DIODE CONFIGURATION.
 - b. THE BLOCKING DIODE MUST BE RATED FOR A MINIMUM OF 50 VOLTS AND 10 AMPS
6. THE 24 VDC RETURN, "DC (-)," SHALL BE USED AS THE LOW SIDE OF THE FILE SELECT RELAYS.
7. THE 24 VDC RETURN, "DC (-)," IS THE RETURN FOR THE 4–20 MA OUTPUT LOOP(S). INPUT MUST BE ISOLATED TYPE. THE MAXIMUM CURRENT LOOP RESISTANCE IS 750 OHMS.
8. CONNECT THE SCANNER EARTH GND (GREEN/YELLOW, 8, <H>) TO EARTH GROUND. A SHORT-BRAIDED CONDUCTOR (ALTERNATELY A SHORT AWG #12 WIRE) IS RECOMMENDED.
9. ALL SHIELDS ARE TIED TO EARTH GROUND IN THE CONTROL PANEL ONLY.



CAUTION

- ELECTRICAL NOISE INTERFERENCE FROM HIGH VOLTAGE/ENERGY IGNITION SOURCES CAN ADVERSELY AFFECT THE OPERATION OF THE FLAME SCANNER.
- DO NOT INSTALL IGNITION WIRES IN THE SAME CONDUIT AS THE SCANNER WIRES.
- IGNITION SYSTEMS SHALL HAVE A DEDICATED RETURN.
- DO NOT MOUNT AN IGNITION TRANSFORMER IN THE SAME ENCLOSURE WHERE THE FLAME SCANNER WIRING IS TERMINATED.
- IGNITION CABLES SHALL BE ROUTED A MINIMUM OF 12 in (305 mm) FROM SCANNER WIRING.

6.3.1 Wiring Diagram (4-wire config file select)

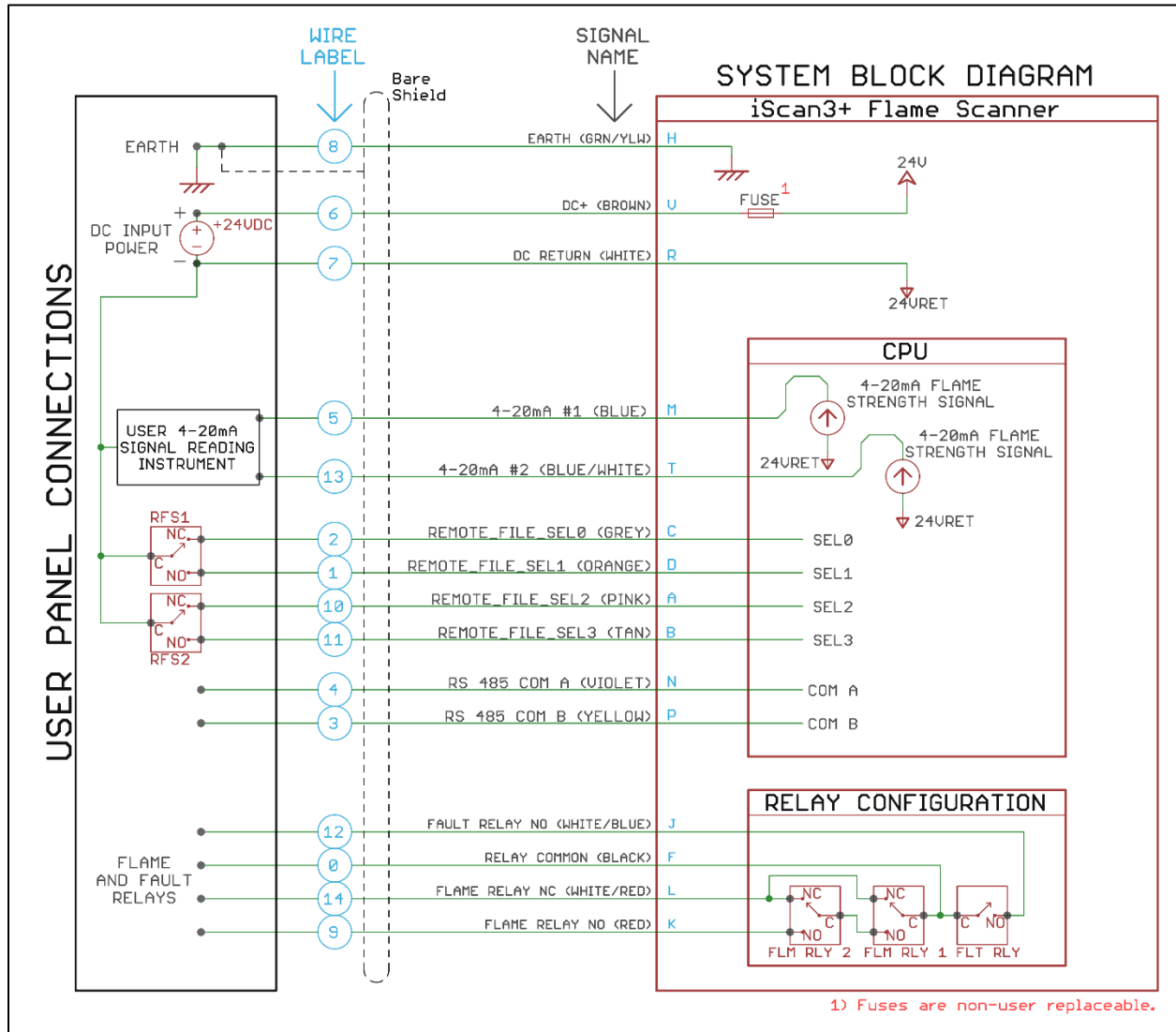


Figure 7: iScan3+ Wiring Diagram

6.3.2 Wiring Diagram (2-wire config file select)

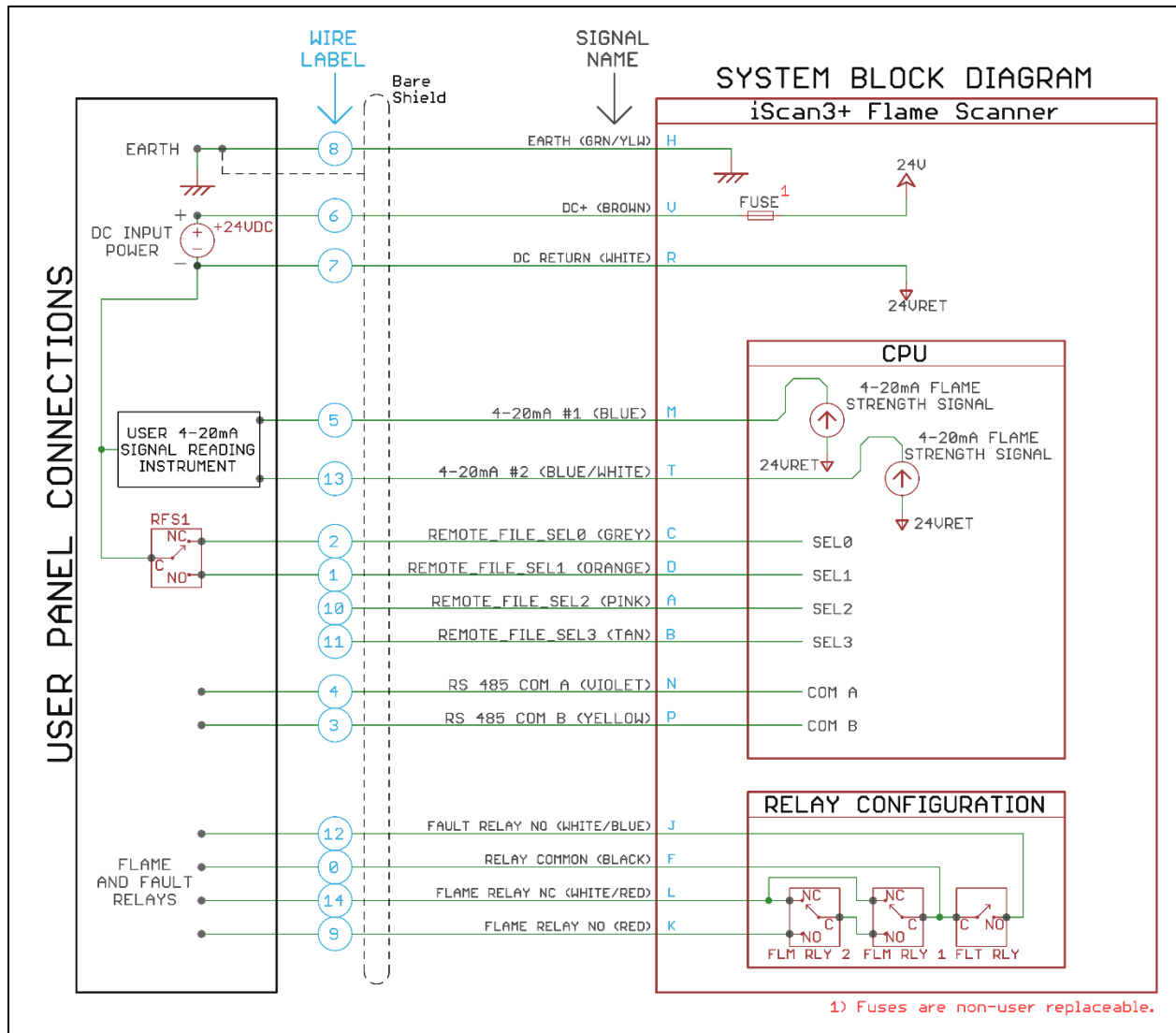


Figure 8: iScan3+ Wiring Diagram

6.4 RS-485 Wiring Configurations



1. 24 VDC RETURN, "DC (-)", MUST BE USED AS THE SIGNAL REFERENCE
2. THE USB TO RS-485 CONVERTER AND THE REPEATER(S) MUST HAVE THEIR GND TERMINALS CONNECTED TO DC (-)
3. FAILURE TO PROVIDE THE SIGNAL REFERENCE MAY RESULT IN COMMUNICATION ERRORS AND POTENTIALLY DAMAGE ISCAN3+

(Configurations shown on next pages.)

6.4.2 Split (Y Chain) Wiring Configuration

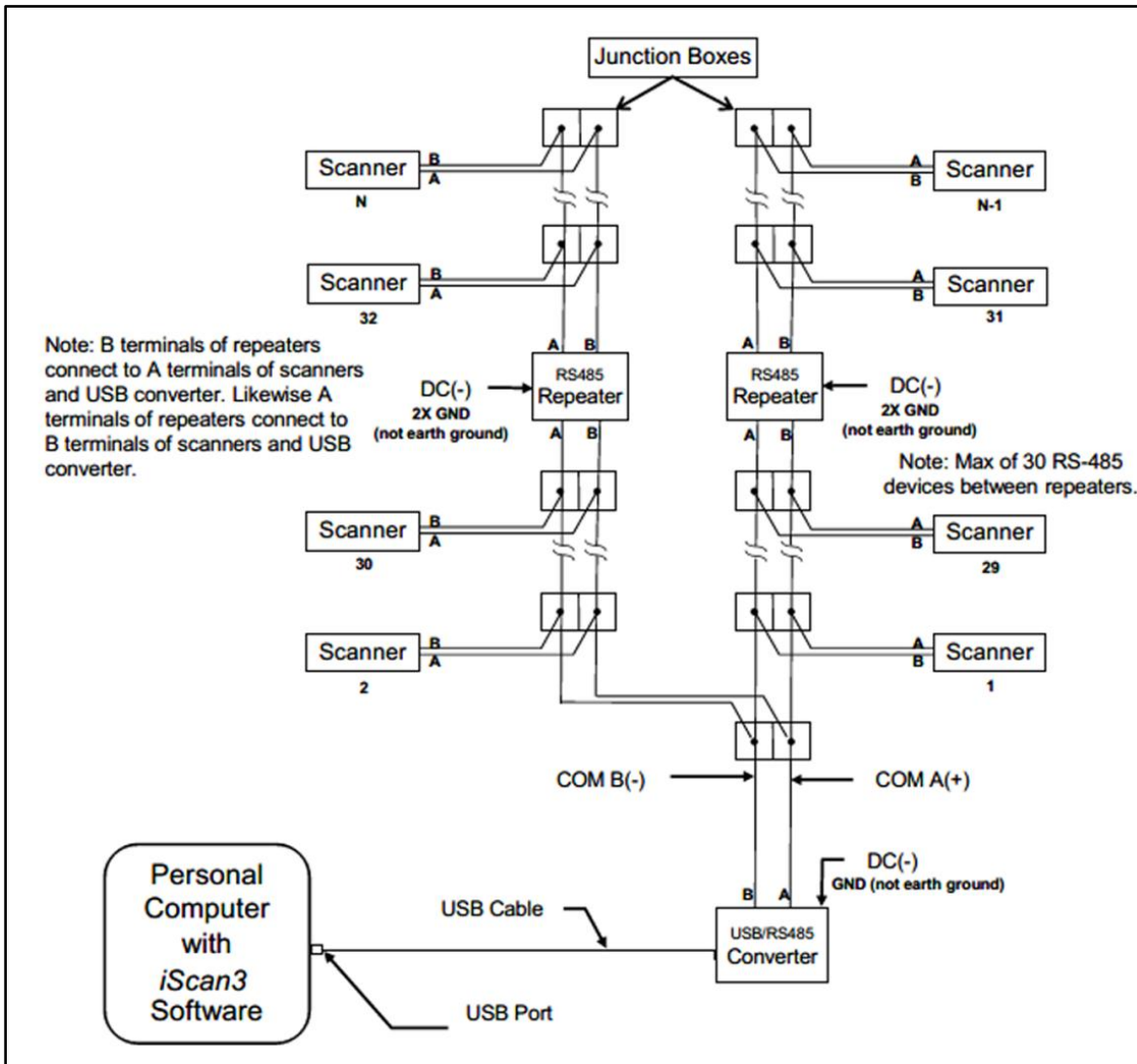


Figure 10: Split (Y Chain) Wiring Configuration

6.5 Configuration File Select Wiring



1. USE DRY RELAY CONTACTS PER INFORMATION IN THE FOLLOWING SECTIONS
2. CONNECT RELAY COMMON (C) TO 24VDC RETURN (-)
3. FILE SELECT CONFIGURATIONS ARE WIRE FAULT PROTECTED: THE SCANNER WILL FAULT IF ANY WIRE COMBINATION IS BROKEN, (LOOSE WIRE CONNECTION, CUT WIRE, ETC.)
4. SWITCHING MUST OCCUR IN LESS THAN 800ms.
5. REFER TO THE "REMOTE FILE SELECT" SECTION OF **MNL-ISCAN SOFTWARE** FOR MORE INFORMATION

(Configurations shown on next pages.)

6.5.1 Four-Wire Input (Two Control Relays)

Table 17: Config File Select, Four Wire Input				
Config File	Select Line			
	SEL 0	SEL 1	SEL 2	SEL 3
A	Open/floating	Connect to DC Return (-)	Open/floating	Connect to DC Return (-)
B	Open/floating	Connect to DC Return (-)	Connect to DC Return (-)	Open/floating
C	Connect to DC Return (-)	Open/floating	Connect to DC Return (-)	Open/floating
D	Connect to DC Return (-)	Open/floating	Open/floating	Connect to DC Return (-)

Table 18: Relay Status, Four Wire Input		
Config File	Control Relay 1	Control Relay 2
A	ON	ON
B	ON	OFF
C	OFF	ON
D	OFF	OFF

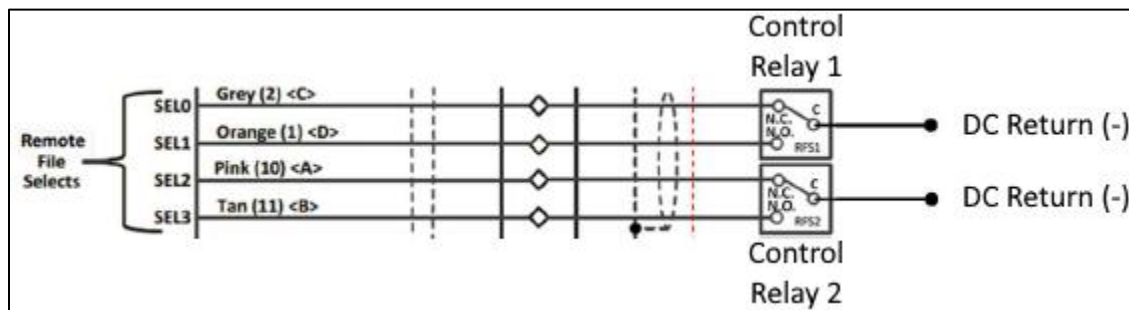


Figure 11: Schematic Diagram of Four-Wire Input

6.5.2 Two-Wire Input (One Control Relay)

Table 19: Config File Select, Two Wire Input		
Config File	Select Line	
	SEL 0	SEL 1
B	Open/floating	Connect to DC Return (-)
C	Connect to DC Return (-)	Open/floating

Table 20: Relay Status, Two Wire Input	
Config File	Control Relay
B	ON
C	OFF

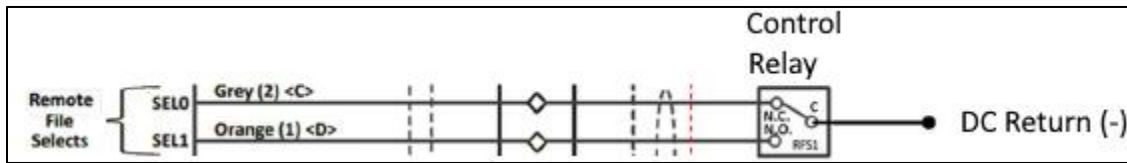


Figure 12: Schematic Diagram of Two-Wire Input

6.5.3 Wire Color Maps

Depending on the application, the iScan3+ will be paired with either the standard or marine grade I/O Harness (see Section 8 for PNs).

Table 21: Standard Colors		
Wire No.	Function	Wire Color
0	Relay common	Black
1	File select 1	Orange
2	File select 0	Grey
3	RS485 communication B	Yellow
4	RS485 communication A	Violet
5	4-20 mA #1	Blue
6	DC (+)	Brown
7	DC (-)	White
8	Earth ground	Green and yellow
9	Flame relay N.O.	Red
10	File select 2	Pink
11	File select 3	Tan
12	Fault relay N.O.	White with blue stripe
13	4-20 mA #2	Blue with white stripe
14	Flame relay N.C.	White with red stripe
15	Unused	Violet with black stripe
16	Unused	Yellow with black stripe
17	Unused	White with black stripe
Drain	Drain	Bare

Table 22: Marine Colors

Wire No.	Function	Wire Color
0	Relay common	Black
1	File select 1	Orange
2	File select 0	Black with white stripe
3	RS485 communication B	Yellow
4	RS485 communication A	Violet
5	4-20 mA #1	Black with blue stripe
6	DC (+)	Black with orange stripe
7	DC (-)	White
8	Earth ground	Green (may appear teal)
9	Flame relay N.O.	Red
10	File select 2	Black with red stripe
11	File select 3	Black with yellow stripe
12	Fault relay N.O.	Black with violet stripe
13	4-20 mA #2	Black with green stripe (may appear teal)
Drain	Drain	Bare

Table 23: Marine Colors (Alternative)

Twisted Pair No.	Function	Wire Color
1	DC (+)	Blue
1	DC (-)	White
2	Earth ground	Blue
2	Relay common	White
3	Flame relay N.O.	Blue
3	Fault relay N.O.	White
4	4-20 mA #1	Blue
4	4-20 mA #2	White
5	RS485 communication A	Blue
5	RS485 communication B	White
6	File select 0	Blue
6	File select 1	White
7	File select 2	Blue
7	File select 3	White
-	Drain	Bare

6.6 Initial Setup of the iScan3+

Proper flame sighting is required for proper flame scanner detection and discrimination. The view through the sight port should be the full flame, as illustrated in **Figure 13**.



Figure 13: Sight Port View

6.6.1 Aiming an SB/SB4 Model

- With the target flame on, aim the scanner such that there is a full view of the flame, as shown in **Figure 13**.
- Using the Ring of Light as a guide, aim the scanner such that a strong or good flame signal is achieved. Automatic gain is enabled on SB models so iScan3+ will adjust its gain level to try and reach an acceptable flame signal level.
 - Refer to **Table 4** for examples of how the Ring of Light should look.

6.6.2 Aiming an MB Model

- With the target flame on, aim the scanner such that there is a full view of the flame, as shown in **Figure 13**.
- *iScan Software* is required to configure or “tune” the scanner to the application.
 - By default, an MB model is configured with gain set to its lowest level. The automatic gain setting is disabled so the signal gain needs to be manually adjusted. *Typically, a factory default MB model will not detect a flame.*
- There are two methods to set an acceptable gain level during the aiming process:
 - Utilizing the “Learn Gain” function within *iScan Software*.
 - Utilizing the “Learn Flame ON” / “Learn Flame OFF” functions.
 - Refer to **MNL-iScan Software** for more information.

6.6.3 Advanced Aiming

When the scanner gain is set to maximum (all purple LEDs ON) or adjusted to a specific value, precise aiming can be performed using the iScan® Live mobile app or iScan® software. Slowly adjust the scanner position in small increments, pausing for approximately 5 seconds between adjustments to allow the app data to stabilize. Monitor the AC dB value closely, aiming for a reading near or above 0, as this indicates a strong signal and optimal alignment.

7 Product Maintenance

7.1 Cleaning the Lens

Occasionally it may be necessary to clean the iScan3+ focal lens.

1. Disconnect the iScan3+ from the I/O Harness.
2. To access the lens, remove the CAM by unscrewing counterclockwise.
3. Clean the lens with a clean, damp, lint-free cloth or screen cleaning wipe.
4. Replace the CAM and reinstall the scanner.



WARNING

1. DO NOT PERFORM THIS ACTION WHILE THE UNIT IS POWERED AND IN SERVICE AS IT WILL OPEN THE FLAME RELAY INDICATING LOSS OF FLAME. IF THIS IS A REDUNDANT SYSTEM AND THE OTHER SCANNER IS DETECTING FLAME THEN PROCEED AT YOUR OWN RISK, KNOWING THAT THE OTHER SCANNER IS THE ONLY SCANNER PROOVING FLAME.
2. DO NOT ATEMPT TO REMOVE THE LENS FROM THE iScan3+ HOUSING. THIS WILL VOID CERTIFICATIONS ON THE UNIT AND VOID THE WARRANTY.

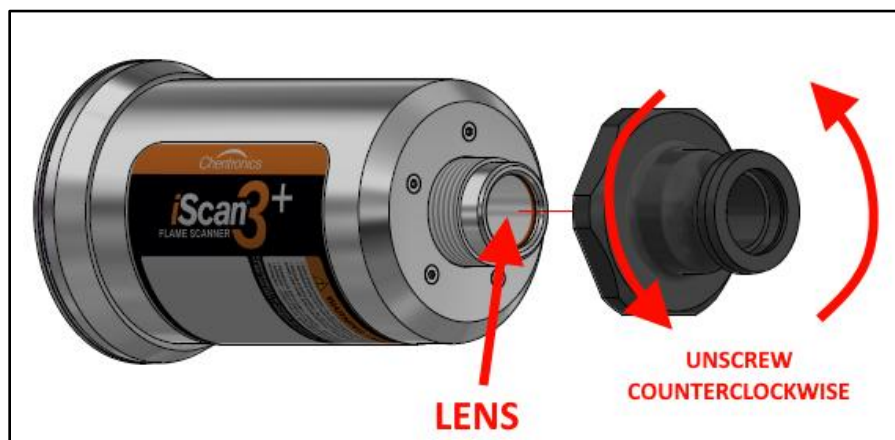


Figure 14: Lens Location

7.2 Cleaning the Enclosure

It's not uncommon for items in power plants or installed outdoors to accumulate dust, dirt, or other contaminants. It's highly recommended that the iScan3+ be wiped down from time to time with a clean, damp, cloth or rag. Ensure that the product label always remains legible and visible.


7.3 SIL Proof Testing [PENDING]

SIL evaluation is currently underway for the iScan3+ and this section will be updated once it has been completed.

8 Accessories

Table 24: Accessory List																
I/O Harness (Standard)	03005000															
I/O Harness (Marine)	03MG5000 or 03MG5001															
Camlock Coupling	04005036 (female NPT threads) 04005042 (male NPT threads)															
USB to RS-485 Converter Kit	07005113															
Recommended Repeater	Advantech model BB-485OPDRI-PH															
	Dip Switch Settings															
	<table border="1" style="margin-left: auto; margin-right: auto;"> <tr> <td>1</td><td>2</td><td>3</td><td>4</td><td>5</td><td>6</td><td>7</td><td>8</td> </tr> <tr> <td>ON</td><td>ON</td><td>ON</td><td>ON</td><td>OFF</td><td>OFF</td><td>ON</td><td>OFF</td> </tr> </table>	1	2	3	4	5	6	7	8	ON	ON	ON	ON	OFF	OFF	ON
1	2	3	4	5	6	7	8									
ON	ON	ON	ON	OFF	OFF	ON	OFF									
Panel Mounted Ring of Light	04005815															
Swivel Mount Assembly	2401-644															
Flame Simulator	04005700															
Power Supply (PSDM3)	04005800															
IR Filter	IR KIT [04005100] or 04000120 [field upgrade kit]															
Fiber Optic Hardware (FOX)	For information on configuring a FOX scope of supplies, an application guide is available upon request.															

9 Technical Support





Inside USA Call: 607.334.5531

Outside USA Call: +1.607.334.5531

Website: Chentronics.com/Literature-Support

Email: Sales@Chentronics.com

9.1 Troubleshooting Guide

Table 25: Troubleshooting Chart		
Symptom	Potential Cause	Potential Solution
Low flame signal	Lens has contamination	Clean the lens per Section 7.1
Low flame signal	Scanner is not aimed properly	Refer to Section 6.6 for information on how to aim iScan3+
4-20 mA signal reads between 1 to 3 mA	Warning or fault detected	Refer to Section 9.2 for fault descriptions
Right half of LEDs are blinking yellow	Temperature warning	Refer to Section 12 for Ring of Light behavior examples and Section 9.2 for warning descriptions
All LEDs are blinking yellow	Temperature fault	Refer to Section 12 for Ring of Light behavior examples and Section 9.2 for fault descriptions
Single LED blinking yellow	Fault detected	Refer to Section 9.2 for fault descriptions
Single LED solid yellow	Scanner disabled	Refer to Section 9.2 for fault descriptions
Single LED blinking blue	Bluetooth failed to initialize. Note: The scanner will continue to operate normally if Bluetooth fails to initialize.	Power cycle the scanner

9.2 Warning and Fault Operation

iScan3+ performs device temperature monitoring and self-checking of essential functions on a routine interval when powered. Temperature monitoring and self-checking will produce warning and fault operating mode. These modes are described in the following table:

Table 26: Warning and Fault Operation Modes			
Mode	Description	Flame Relay Operation	4-20 mA Output
Normal	Device temperature is within rated range.	Normal	Normal (4 to 20 mA)
Temperature Warning	Device temperature is approaching upper or lower rated limits.	Normal	3 mA steady
Temperature Fault	Device temperature is above or below rated temperature limits.	Relays open and remain open until device temperature returns to within the rated range.	2 mA steady
Fault	Device has experienced a fault during self-checking. Fault may clear upon power reset.	Relays open and remain open until the fault has been cleared.	1.5 mA steady
Disable	Device temperature has exceeded the absolute maximum temperature limit.	Relays are permanently disabled and will not close.	1 mA steady

9.3 Special, “X” Conditions of Use

1. The equipment must only be used in an area with a low impact risk.
2. The equipment must be used in an area free from falling debris.
3. The equipment must be placed in an area with no mechanical hazard.
4. The equipment must not be subjected to human abuse.

9.4 Warranty Instructions

For warranty-related inquiries, please contact Chentronics at TEL: +1.607.334.5531 or info@chentronics.com

10 Appendix A: MODBUS User Message

10.1 PC COM Port Settings

Baud rate: 19200

Byte size: 8 bits

Parity: None

Stop bits: 1

10.2 MODBUS Function Code and Registers

10.2.1 MODBUS Function Code

Read Input Registers – 0x04

10.2.2 Input Register Address

Address	Field	Input Range	Output Range	Data Type	Conversion
0	Two High digits of SN	0x70	"70"	Hex string	NA
1	Two Mid digits of SN	0x00 ~ 0x99	"00" ~ "99"	Hex string	NA
2	Two Low digits of SN	0x00 ~ 0x99	"00" ~ "99"	Hex string	NA
3	Low digit of SN Prefix	0~255	0~255	ASCII char	NA
4	Mid digit of SN Prefix	0~255	0~255	ASCII char	NA
5	High digit of SN Prefix	0~255	0~255	ASCII char	NA
6	WOM week	0 ~ 52	0 ~ 52	unsigned byte	O = I
7	WOM year	0 ~ 99	0 ~ 99	unsigned byte	O = I
8	Manufacture Code	0~255	0~255	ASCII char	C = "Chentronics"
9	Threshold Value	0 ~ 255	-58 ~ 5.75dB	unsigned byte	$O = (I - 232) / 4.0$
10	Flame Frequency	0 ~ 255	0 ~ 255Hz	unsigned byte	O = I
11	Band Width	0 ~ 255	0 ~ 255Hz	unsigned byte	O = I
12	Maximum Temperature	-128~127	-128 ~ 127°C	signed byte	O = I
13	Minimum Temperature	-128~127	-128 ~ 127°C	signed byte	O = I
14	Maximum Input Voltage	0 ~ 255	50 ~ 0V	unsigned byte	$O = (5 - I \times 5 / 255) \times 10$
15	Minimum Input Voltage	0 ~ 255	50 ~ 0V	unsigned byte	$O = (5 - I \times 5 / 255) \times 10$
16	Firmware Sub-revision digit 0	0 ~ 255	0 ~ 255	unsigned byte	Sub-revision = digit0.digit1
17	Firmware Sub-revision digit 1	0 ~ 255	0 ~ 255	unsigned byte	
18	Firmware Revision	70 ~ 79	7.0 ~ 7.9	unsigned byte	O = I / 10
19	Temperature	-128~127	-128 °C ~ 127°C	signed byte	O = I
20	Flame Status, Fault and Warning BitField	0 ~ 65535	NA	BitField	Flame Status, Fault and Warning BitField
21	Gain	0 ~ 4095	0 ~ 1000	unsigned short	O = I / 4.095
22	Average DC Voltage	0 ~ 1024	0 ~ 5V	unsigned short	O = I / 204.6

23	Average AC Voltage	0 ~ 65535	0 ~ 30.89V	unsigned short	$O = I / 2121.58$
24	Flame Flicker Strength	-32768~32767	-78.02 ~ 78.01dB	signed short	$O = I / 420$
25	Input Voltage	0 ~ 255	50 ~ 0V	unsigned byte	$O = (5 - I \times 5 / 255) \times 10$
26	Input Current	0 ~ 255	0 ~ 497.51mA	unsigned byte	$O = I \times 1.951$
27	Current Config File Num	0 ~ 3	A, B, C, D	unsigned byte	0 = A, 1 = B, 2 = C, 3 = D
28	First Out Byte	0~255	NA	unsigned byte	First Out Byte Description
29 – 156	Flame Frequency Domain Data (0 – 256Hz, 2Hz resolution)	-128~127	-128 ~ 127dB	signed byte	$O = I$
157 – 412	AC signal data (0 – 500ms, 512Hz sampling rate)	0~255	0 ~ 5V	unsigned byte	$O = I \times 5 / 255$

10.3 Common Structures and Bit Fields

10.3.1 Flame Status, Fault and Warning Bit Field

Table 24: Flame Status, Fault and Warning Bit Field (Unsigned Short)			
Bit	Field	Comments	Data Type and Conversion
0	WARN_LOW_TEMP	Low temperature warning 1=w/ warning, 0=w/o warning	1 bit
1	WARN_HIGH_TEMP	High temperature warning 1=w/ warning, 0=w/o warning	1 bit
2	FAULT_LOW_TEMP	Low temperature fault 1=w/ fault, 0=w/o fault	1 bit
3	FAULT_HIGH_TEMP	High temperature fault 1=w/ fault, 0=w/o fault	1 bit
4	FAULT_CRITICAL	Other Critical faults 1=w/ fault, 0=w/o fault	1 bit
5	WARN_LOW_VOLT	Lower input voltage warning 1=w/ fault, 0=w/o fault	1 bit
6	RESERVED1	Reserve for future use	1 bit
7	RESERVED2	Reserve for future use	1 bit
8	FLAMESTATBIT	1=flame on; 0=flame off	1 bit
9	HIGHGAINSTATUS	1=high gain; 0=low gain	1 bit
10	AUTOGAINSTATUS	1=auto gain; 0>manual gain	1 bit
11	RAIL_RULE_BIT	1=pass; 0=fail	1 bit
12	MAINS_RULE_BIT	1=pass; 0=fail	1 bit
13	FLAME_RULE_BIT	1=pass; 0=fail	1 bit
14	SOLAR_RULE_BIT	1=pass; 0=fail	1 bit
15	THRESHOLD_RULE_BIT	1=pass; 0=fail	1 bit

10.3.2 First Out Byte Information

Table 25: First Out Byte Description (Unsigned Byte)	
Byte Value	First Out Message
0xFF	None
0x00	Critical Fault
0x20	Total Flame Loss: Avg Flame Signal Below -54dB
0x31	Rail PSL: AC Avg Exceeds AC Avg Max
0x32	Rail PSL: DC Avg Exceeds DC Avg Max
0x41	Flame PSL: Band Pass within 4Hz of Main and Main Exceeds 20 Hz Level
0x42	Mains PSL: Mains Exceed Peak Threshold
0x51	Flame PSL: Level at 40Hz less than Level at 200Hz + Offset
0x61	Solar PSL: Gain Exceeds Max Solar Gain
0x62	Solar PSL: Average Frequency Exceeds Solar Freq Max
0x70	Marg Flame Loss: Avg Flame Signal Below Threshold
0x80	Sensor Noise Exceeds Threshold

